

Home Builders Guide to Ducts in Conditioned Space



DESIGN GUIDELINES

October 2003
P500-03-082-A16



Gray Davis, *Governor*

CALIFORNIA ENERGY COMMISSION

Prepared By:

Gard Analytics, Inc.

Roger Hedrick, Lead Author
Park Ridge, IL

Managed By:

New Buildings Institute

Cathy Higgins

Program Director

White Salmon, WA

CEC Contract No. 400-99-
013

Prepared For:

Donald Aumann,

Contract Manager

Nancy Jenkins,

***PIER Buildings Program
Manager***

Terry Surles,

PIER Program Director

Robert L. Therkelsen

Executive Director

DISCLAIMER

This report was prepared as the result of work sponsored by the California Energy Commission. It does not necessarily represent the views of the Energy Commission, its employees or the State of California. The Energy Commission, the State of California, its employees, contractors and subcontractors make no warrant, express or implied, and assume no legal liability for the information in this report; nor does any party represent that the uses of this information will not infringe upon privately owned rights. This report has not been approved or disapproved by the California Energy Commission nor has the California Energy Commission passed upon the accuracy or adequacy of the information in this report.

Acknowledgements

The products and outcomes presented in this report are a result of funding provided by the California Energy Commission's Public Interest Energy Research (PIER) program on behalf of the citizens of California. Gard Analytics would like to acknowledge the support and contributions of the individuals below:

Project Director: Roger Hedrick, GARD Analytics, Inc.

Technical Assistance: Geof Syphers, XENERGY; Rob Hammon, Steve Vang and Bruce Bacceti, ConSol; Bill Irvine, BCI Testing. Additional technical review by Alan Cowan, New Buildings Institute.

Review and Advisory Committee: Rick Chitwood, Chitwood Energy Management; Iain Walker, Lawrence Berkeley National Laboratory; Joe Lstiburek, Building Science Corporation; Bruce Wilcox, Berkeley Solar Group; Jamie Lyons, Energetics, Inc; Marshall Hunt, Pacific Gas and Electric.

Project Management: Cathy Higgins, Program Director, New Buildings Institute; Don Aumann, Contract Manager, California Energy Commission.

Preface

The *Home Builders Guide to Ducts in Conditioned Space* (Builders Guide) is a part of the *Integrated Energy Systems: Productivity and Building Science* project, a Public Interest Energy Research (PIER) program. It was funded by California ratepayers through California's System Benefit Charges administered by the California Energy Commission (Commission) under PIER contract No. 400-99-013, and managed by the New Buildings Institute. The PIER program supports public interest energy research and development that will help improve the quality of life in California by bringing environmentally safe, affordable, and reliable energy services and products to the marketplace.

The Builders Guide is a product of a three-year research project that included the testing of 18 homes with the duct system located in the conditioned space using one of three different approaches: dropped ceiling; unvented conditioned "cathedralized" attic; and attic plenum. Detailed descriptions are provided that focus on the construction techniques and details that production builders will need to successfully incorporate each approach. Appendices provide house plans and construction protocols for subcontractors to follow when building houses with ducts in conditioned space, as well as a list of additional research resources. Related documents are referenced throughout this document.

The *Integrated Energy Systems: Productivity and Building Science* program consisted of six distinct research elements, including this one on residential ducting systems. A Final Report is available that provides a complete record of the objectives, methods, findings and accomplishments of the entire project. The Final Report will be of interest to architects, designers, contractors, building owners and operators, manufacturers, researchers, and the energy efficiency community.

The Buildings Program Area within the Public Interest Energy Research (PIER) Program produced this document as part of a multi-project programmatic contract (#400-99-413). The Buildings Program includes new and existing buildings in both the residential and the non-residential sectors. The program seeks to decrease building energy use through research that will develop or improve energy efficient technologies, strategies, tools, and building performance evaluation methods.

The Builders Guide is Attachment A-16 (product 6.3.4) to the Final Report on *Integrated Energy Systems: Productivity and Building Science* Program (Commission Publication # P500-03-082). For more information about the PIER program, or to obtain the Final Report and other publications produced by this project, please visit www.energy.ca.gov/pier or contact the Commission's Publications Unit at 916-654-5200. All research products are also available through New Buildings Institute at www.newbuildings.org/pier.

Abstract

New homes in California are typically built with the air handler and ductwork located in an unconditioned attic. Research confirms large energy losses from these systems, primarily due to air leaks in the air handler and duct system, but also including heat conducted through the duct material. These losses are especially problematic in the summer when solar radiation can elevate the attic temperature well above the outdoor air temperature. Moving the ductwork into the conditioned space can save 8% to 15% of the air-conditioning costs for homeowners.

The *Home Builders Guide to Ducts in Conditioned Space* is written for builders, contractors and subcontractors providing them with sufficient detail that existing house designs can be modified to be built with the ducts in the conditioned space. Three approaches are described: Dropped Ceiling, Cathedralized Attic, and Plenum Truss. The three approaches are the same in that the ductwork is installed below the roof insulation and air barrier, but vary by where the roof insulation is installed. The changes to standard practice are identified by trade for each approach as well as the advantages and disadvantages. Three appendices provide house plans, construction protocols for subcontractors to follow when building houses with ducts in conditioned space, and additional research resources.

Author: Roger Hedrick, Gard Analytics, Inc.

Keywords: Ducts, Duct Placement, Attic Temperature, Duct Energy Losses, Home Builders, Builders, Builders Guide, Air Conditioning

Table of Contents

Acknowledgements.....	i
Preface	ii
Abstract.....	iii
Table of Contents	iii
Overview	1
Introduction.....	3
The Problem with Ducts in Unconditioned Space	3
The Solution: Placing Ducts in Conditioned Space	4
Energy Savings and Cost Estimates	6
Additional Publications	7
Dropped Ceiling.....	9
Designer.....	9
Framer.....	10
HVAC Contractor.....	10
Drywall Contractor.....	11
Insulation Contractor.....	11
Other Trades	11
Advantages.....	12
Disadvantages.....	12
Cathedralized Attic	15
Designer.....	16
Roofer.....	17
Insulation Contractor.....	17
HVAC Contractor.....	18
Advantages.....	18
Disadvantages.....	19
Plenum Truss	21
Designer.....	22
Framer.....	22
Insulation Contractor.....	22
HVAC Contractor.....	22
Advantages.....	23

Disadvantages.....	23
Multi-Story Houses	25
Designer.....	26
Framer.....	26
Insulation Contractor.....	26
HVAC Contractor.....	27
Drywall Contractor.....	27
Appendix A. Construction Protocols for Ducts in Conditioned Space	29
Introduction.....	29
1. Subcontractor/Field Coordination	29
2. Dropped Ceiling Approach	29
3. Cathedralized Attic Approach.....	31
4. Plenum Truss Approach.....	32
5. Multi-Story Houses.....	34
APPENDIX B. California House Plans with Example Dropped Ceiling Locations.....	37
APPENDIX C. References & Additional Resources.....	41

Overview

This Builders Guide provides recommended techniques for building homes with ducts in conditioned space. These techniques are proven and have been successfully used in production homes, although they are not yet widely used.

Building new houses with the ducts inside conditioned space will provide significant savings on home energy bills, even when compared to sealed and tested duct systems. The impact on construction costs can be very low, depending on house size and configuration.

The Introduction to this Builders Guide gives background information about the problems with ducts in *unconditioned* space, and briefly describes the advantages of building new homes with ducts inside *conditioned* space. Information about energy savings, construction cost impacts, and market barriers and solutions also appears in the Introduction, as well as a list of related publications developed as part of this project.

Following the Introduction, the Builders Guide provides a chapter dedicated to each of the recommended construction approaches—Dropped Ceiling, Cathedralized Attic, and Plenum Truss.

- The **Dropped Ceiling** approach uses dropped ceilings within portions of the house, such as above hallways and closets, to contain the ductwork within conditioned space.
- The **Cathedralized Attic** design moves the insulation to the roof plane and eliminates attic venting, creating a semi-conditioned space above the ceiling.
- The **Plenum Truss** approach uses a modified scissors truss to create space for the ducts between the ceiling and the bottom chord of the truss that is then inside the conditioned space.

For each approach, changes to standard practice are identified by trade. The advantages and disadvantages of each approach are also described. A chapter on Multi-Story Houses addresses the additional issues and requirements, regardless of approach, for the area between floors.

Construction protocols are given in an Appendix to allow the requirements to be easily transferred to a subcontractor or into a contract. Additional Appendices include sample floor plans incorporating the dropped ceiling approach, and resources on duct placement research.

Introduction

The Problem with Ducts in Unconditioned Space

New houses in California typically are built with the air handler and ductwork located in the unconditioned attic. The ductwork is commonly built with ductboard plenums and flex duct, insulated to R4.2, or sometimes R6 (code requirement is R4.2). In recent years, numerous studies have found large energy losses from these systems, primarily due to air leaks in the air handler and duct system, but also caused by heat conducted through the duct material. These losses are especially problematic in the summer when solar radiation can elevate the attic temperature well above the outdoor air temperature. Previous studies found that typical duct systems lose over 30% of the space conditioning energy consumed by the HVAC system.¹

Air leaks on the supply side of the system are lost to the unconditioned attic and eventually to the outdoors, while leaks on the return side result in unconditioned air being brought into the system, increasing the space conditioning load. Unbalanced leakage (for example, large supply leaks with small return leaks) can significantly affect the air pressure in the house, resulting in increased infiltration and a corresponding increase in space conditioning loads. Leakage can also cause comfort problems by reducing supply air flow to the house or to individual rooms, and by increasing infiltration.

The problem of duct leakage has primarily been addressed through a variety of programs aimed at reducing leakage in the duct system. These include several utility company programs that provided duct leakage testing and training to duct installers. The Title 24 Alternative Calculation Method (ACM) manual now includes a credit for ducts with tested leakage below 6% of system airflow. These programs have reduced typical duct leakage in new construction, down from historical values of 30% to 40%, but few builders currently take advantage of the Title 24 energy credit. Typical duct leakage values are still around 20% to 25% of system airflow in approximately 70% of most new houses, according to our estimates. And ducts are still located in the unconditioned attic where the leaks and thermal conduction are lost to the outdoors.

¹ Jump, D. A., I. S. Walker, M. P. Modera. "Field Measurements of Efficiency and Duct Retrofit Effectiveness in Residential Forced Air Distribution Systems." Proceedings of the 1996 ACEEE Summer Study, Vol. 1, pp 147-155. 1996.

The Solution: Placing Ducts in Conditioned Space

Building new houses with the ducts inside conditioned space will provide significant savings on home energy bills, even when compared to sealed and tested duct systems. The impact on construction costs can be very low, depending on house size and configuration. In some cases, construction costs may actually decrease.

Placing ducts in conditioned space involves modifying the design and construction of the house such that the duct system is located inside both the air barrier and the thermal barrier. Different approaches can be used to make this change, and each has advantages and disadvantages. The three approaches described in this Builders Guide—Dropped Ceiling, Cathedralized Attic, and Plenum Truss—were developed with the intent to find the best compromise between maximizing marketable floor area, minimizing energy cost, and minimizing construction cost impacts, while keeping the construction process as simple as possible.

The large majority of new California homes are built with slab-on-grade foundations. The methods of building homes with ducts in conditioned space are equally applicable to all homes with systems in the attic, whether they have basement or crawlspace foundations. The general techniques of maintaining air- and thermal-barriers on the outdoor side of the ducts to bring them inside conditioned space are applicable to all homes.

Three different approaches are described in subsequent chapters of this Builders Guide, and the changes to standard practice are identified by trade. The advantages and disadvantages of each approach are described as well. Appendices provide floor plans and construction protocols for subcontractors to follow when working on a project building houses with ducts in conditioned space.

Three Approaches

This Builders Guide presents three approaches to building ducts in conditioned space that have been applied to actual houses. These approaches are Dropped Ceiling, Cathedralized Attic, and Plenum Truss. The three approaches are the same in that the ductwork is installed below the roof insulation and air barrier, but vary by where the roof insulation is installed, as shown in Figure 1 below. These three approaches evolved from extensive research conducted in the last three to seven years and have been used in a limited number of homes in California and across the country.

Figure 1. Thermal Barrier and Duct Locations for Different Approaches

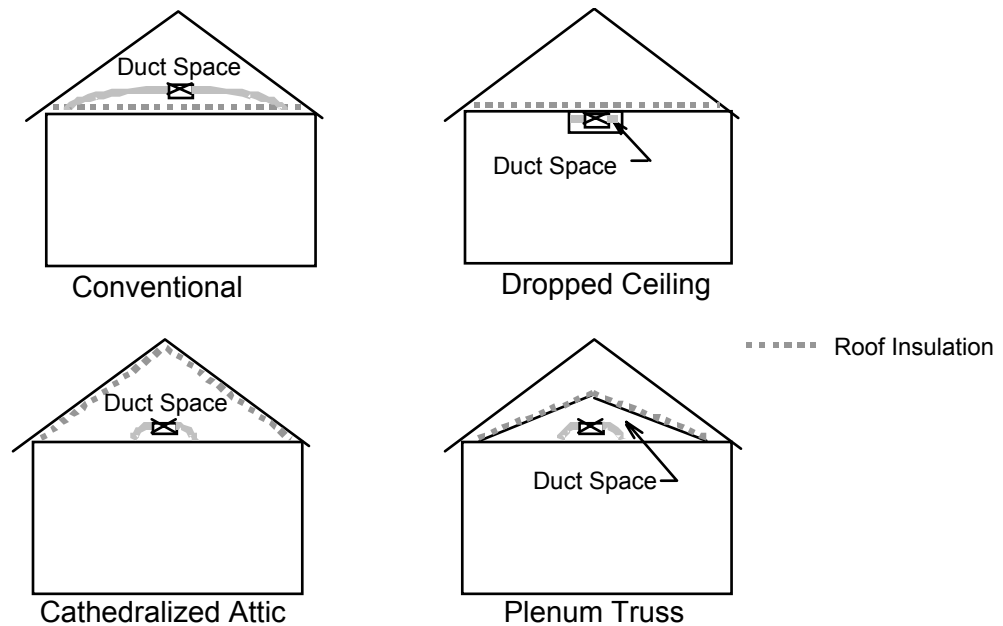

The **Dropped Ceiling** approach is applied to houses with high ceilings, 9 ft to 10 ft. In hallways and other ancillary spaces, a dropped ceiling is installed at 8 ft high, with the ducts installed in the space between. By providing an air barrier at the ceiling height, the duct space is brought into conditioned space. Supply registers are located on interior walls, adjacent to the dropped ceiling.

The **Cathedralized Attic** approach is applied to houses with conventional pitched attics. The roof deck is air sealed to provide the primary air barrier, i.e., ridge and soffit vents are not used. The ceiling insulation is moved to the roof level, and installed immediately below the roof deck. With the air and thermal barriers moved to the roof, the attic is brought into conditioned space. The HVAC system is then installed in the attic as it normally is. The houses that have been built with this approach have generally used interior register locations.

The **Plenum Truss** approach is also applied to houses with conventional attics. A modified scissors truss is used to provide a space between the ceiling and the bottom chord of the trusses. Sheet material, such as fiberboard, is installed on the bottom chord of the trusses, and sealed to provide the air barrier. Insulation is then installed above. The space between the bottom chord of the trusses and the ceiling is then inside conditioned space, and used for HVAC system installation. The conditioned duct space may not extend to the full width of the attic, so again interior supply register locations are used.

Interior register locations have been used for most houses built to date with the three approaches discussed in this report. In the past, being near exterior walls was less comfortable than elsewhere in the house. This was due to poor wall insulation and windows with poor U-values allowing the wall surface temperatures to be cold (or hot). This caused the radiant temperature

to be lower (or higher) than the desired space temperature, as well as drafts caused by convective heat transfer. Additionally, windows were sometimes leaky, allowing additional drafts. Locating supply registers near exterior walls allowed the supply air to wash over the exterior wall, bringing the surface temperature closer to the space temperature, and breaking up drafts.

Current California housing, however, has better insulation, lower air leakage, and better windows. Together, these improvements minimize the discomfort effects described above. As a result, houses can be comfortable without exterior supply registers. This allows the use of interior register locations, which provide benefits to the builder through reduced duct material (the duct runs are shorter), and energy benefits because there is less duct surface area, minimizing thermal conduction. With the interior register locations, however, it is desirable to use higher quality registers that will provide better mixing in the space.

Typical Houses

In this Builders Guide, three typical house designs are used to provide examples of how to build homes with ducts in conditioned space. The three houses selected are Design A (one-story), Design B (two-story) and Design C (townhouse). These designs were selected on the basis that their floor plans lend themselves to application of the Dropped Ceiling approach better than the other designs, although all nine designs appear to be suitable for all three approaches. Floor plans for each house are shown in Appendix A.

Design A is a 1,746-square-foot, single-story house. It has three bedrooms and two baths. Design B is a 3,148-square-foot, two-story house. It has six bedrooms and three baths. Design C is a 1,216-square-foot townhouse. It has two bedrooms and two baths.

Energy Savings and Cost Estimates

What follows is a brief overview of estimated construction costs and energy savings for houses built with ducts in conditioned space. For more detailed data, see the *Costs and Savings for Houses with Ducts in Conditioned Space: Technical Information Report*, which is described in the Additional Publications section later in this report.

Construction Costs

Construction cost estimates to move the ducts into the conditioned space vary greatly by the size and type of house and the method used. Cost impacts vary from zero, or no impact, up to \$4,000 per house, with most houses coming in with costs around \$700. Most paybacks will be within about one year, but with some houses the payback may be up to five years. These costs were obtained from contractors, cost estimating guides, and researcher estimates.

Annual Energy Cost Savings

Moving the ducts into the conditioned space can result in significant energy savings. Models were developed that represented the three construction approaches described in this guideline to estimate the savings from moving the ducts into the conditioned space. As with the construction costs, the

savings vary greatly by the size and type of house, the tightness of the duct system, and the climate zone. For houses with typical duct construction (22% system airflow loss), the average annual cooling electricity savings range from 9% to 18% for single-family houses and 5% to 12% for townhouses. The average cost savings varied from \$415 to \$780 per year for single-family houses and from \$181 to \$207 for multi-family houses.

With approximately 155,000 new residential homes built in California annually there is significant opportunity for energy savings through the adoption of these approaches.

Additional Publications

This Builders Guide is part of a family of resources developed for various groups involved in new home construction, occupant comfort issues, and building codes and energy-efficiency work, including builders, code officials, home buyers, and the California Energy Commission. Many of these resources will also be of interest to other audiences. To obtain these documents, which are described below, please visit the PIER website at www.energy.ca.gov/pier/buildings or contact the Commission's Publications Unit at 916-654-5200. All products are also available through New Buildings Institute at www.newbuildings.org/pier.

- ❑ *Costs and Savings for Houses with Ducts in Conditioned Space: Technical Information Report* (California Energy Commission report 500-03-082 A-31). This document, targeted to the California Energy Commission and Utility Program Managers, describes the estimated cost impacts of building homes with ducts in conditioned space, along with the predicted energy savings. — This document, targeted to code officials discusses a conflict between the building code and one of the techniques for building homes in conditioned space (Cathedralized Attic). It describes the technical basis of the code requirement, and discusses the conditions when the requirement can be safely waived.
- ❑ *Residential Duct Placement: Market Barriers* (California Energy Commission report 500-03-082 A-30). This report describes various market barriers that must be overcome before building homes with ducts in conditioned space becomes widely adopted.
- ❑ *Homeowners Benefits to Ducts in Conditioned Space* (California Energy Commission report 500-03-082 A-17). This brochure describes the benefits of building homes with ducts in conditioned space for the home buyer.

Dropped Ceiling

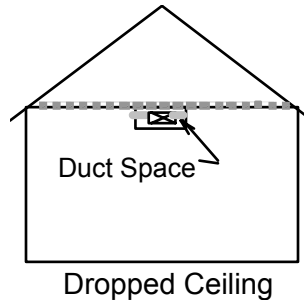

This approach uses the space available in houses built with 9- or 10-foot ceilings to drop the ceiling in hallways and other ancillary spaces by 12 to 20 inches, and use the space between for ductwork. This approach is only useful in houses with high ceilings, and is best applied when rooms are adjacent to or connected by a central hallway which can have the ceiling dropped. It can also be applied by dropping a section of ceiling as a divider between two rooms, and using this to bring the ducts to a remote space (see the floor plan for Design A in the appendix for examples of this).

The critical aspect of constructing a house using the Dropped Ceiling approach is installing the air barrier at the top of the duct space. The air barrier must be continuous, and is best located at the plane of the bottom chord of the roof trusses. Different approaches can be used for this. One method is for the framer to complete only the top of the hallway, with normal drywall installation to establish the air barrier. The HVAC equipment and ductwork is then installed, with ducts suspended from the ceiling or walls. The framers then return to install framing for the bottom of the duct space, cutting through the drywall as needed to attach the new framing to the wall studs, with the drywallers then returning to close in the bottom of the duct space. This approach has the advantage that the HVAC system installation is unimpeded by any framing. There have been problems, however, related to coordination between the various trades. Calling back the framers and drywallers can also incur cost penalties.

An alternative approach is to have the framers complete both the top and bottom of the duct space, using sheet material (OSB, plywood) to cover the top of the duct space. HVAC and ductwork installation in the framed dropped ceiling then proceeds normally, followed by drywall installation. The insulation contractor then seals around the sheet material at the top of the duct space with insulating foam to form the air barrier. In addition, the ceiling drywall in the adjacent rooms must also be sealed to the hallway top plate, thereby forming the required continuous air barrier. This approach has the advantage no trade has to return a second time.

The following text describes steps to install a dropped ceiling duct system, with details for everyone involved in home building. Details are shown in Figure 2.

Designer

1. Review the building plan to identify areas which can have lowered ceiling heights, and therefore are available for use as duct space. See the example floor plans in the appendix.

2. Determine if any spaces are remote from available duct space. If so, evaluate whether a duct soffit can be installed in an architecturally acceptable manner. An example would be to provide a space boundary between a family room and dining area. The appendix contains typical house plans for a one-story house, two-story house and townhouse showing where the dropped ceiling might be installed. Plan 2 in the appendix shows a possible alternate dropped ceiling location that would provide a space boundary between two connected rooms.
3. Identify where the air handler will be installed. If the dropped ceiling duct space is large enough, it might be installed there. Alternatively, it might be installed in a closet off the hallway with the dropped ceiling. This is desirable for energy and maintenance savings, but consumes valuable floor space. A less desirable alternative, from an energy standpoint, is to install the air handler in the unconditioned attic, above the duct space, with supply and return ducts dropping immediately into the conditioned duct space.

Framer

1. Add framing at the dropped ceiling level in the hallways and other areas identified in Designer Step 1. The framers must also construct soffits identified by the designer in Step 2.
2. Install sheet material (OSB, plywood, etc.) above the dropped ceiling duct spaces. This does not have to be elaborately framed. If the bottom chord of the roof trusses are immediately above this space, the material will simply be nailed to the underside of the trusses. If nothing is available for nailing, nails can be partially driven horizontally into the wall top plates, with the sheet material simply laid onto the exposed nail heads. Figure 2 below shows details of constructing the dropped ceiling.

HVAC Contractor

1. Determine if installing ducts in the conditioned space will allow the HVAC system to be downsized. Perform careful sizing calculations following the ACCA Manual J procedure using proper factors for ducts located inside conditioned space. The capacity reduction varies by house size and climate, but should be in the range of $\frac{1}{2}$ to $1\frac{1}{2}$ tons of cooling capacity. Reductions will often, but not always, be sufficient to allow a smaller unit to be installed.
2. The HVAC system is installed with the ducts in the dropped ceiling duct spaces, with the air handler installed in the location identified in Designer Step 3. If a natural draft or induced draft furnace is located in an interior closet, care must be taken to provide adequate combustion air. Sealed combustion furnaces avoid the need for combustion air openings into the air handler location. Supply registers are located on the interior walls adjacent to the duct space.

Drywall Contractor

1. Drywall is installed following usual practice.

Insulation Contractor

1. Seal around the sheet material covering the duct space (see Framing Step 2 and Figure 2) using insulating foam. The connection between the ceiling drywall adjacent to the duct space and the wall top plate must be sealed as well using caulk or insulating foam. The objective is to provide a continuous air barrier at the level of the bottom of the roof trusses. In particular, this means that there must be no openings between the sheet material on top of the duct space, the wall top plate, and the adjacent ceiling drywall. The sealing is only required at the top of the duct space, forming a continuous air barrier at the level of the bottom of the roof trusses.
2. Any electrical or plumbing penetrations through the top of the duct space must be carefully sealed, probably with insulating foam or caulk. If the penetrations are made before insulation is installed, the insulation contractor should systematically locate and seal all openings. If the air handler is located above the duct space, the supply and return ducts penetrating the top of the duct space must also be carefully sealed. Attic insulation may then be installed normally.

Other Trades

1. If penetrations through the top of the duct space are made after insulation is installed, whoever makes the penetration must seal the opening when work is complete.

Figure 2. Construction of a Dropped Ceiling Duct System

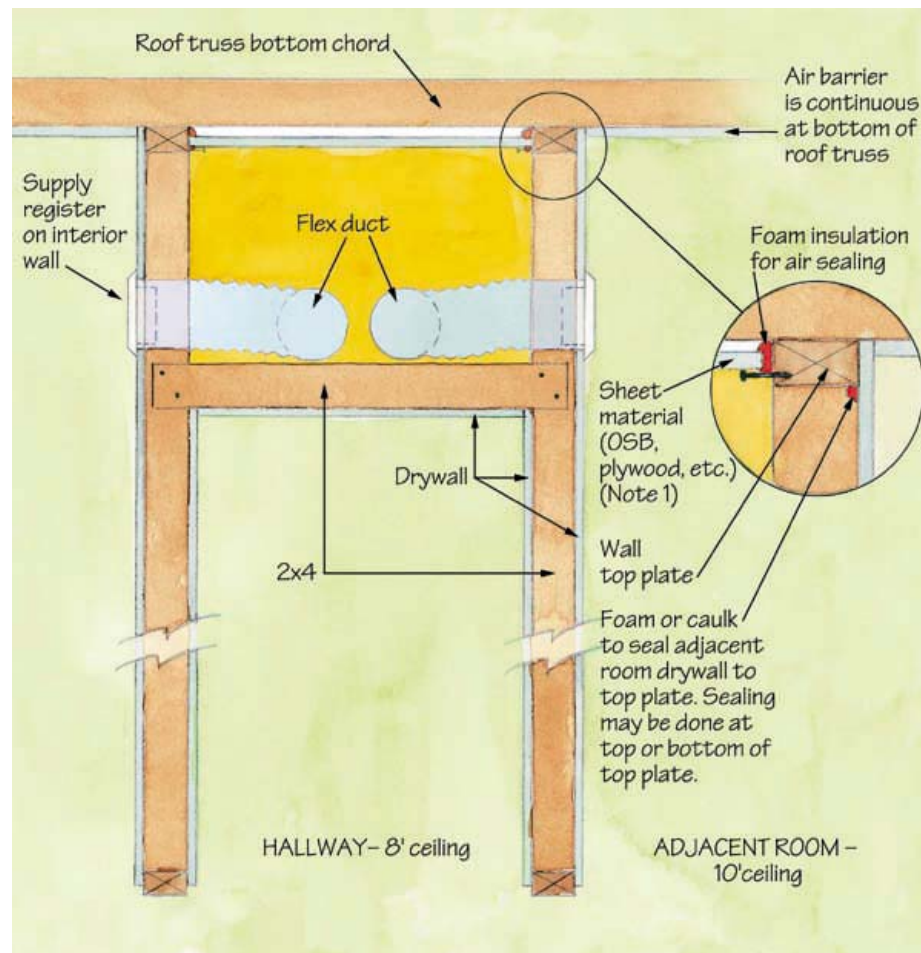

Note: Sheet material may be nailed to underside of roof trusses or laid loosely on horizontal nails. A tight fit is not required, but foam insulation or caulk must seal completely. Foam insulation will help secure the sheet material in place.

Advantages

The Dropped Ceiling approach to installing ducts in conditioned space has several advantages relative to other approaches:

- ❑ No building code impacts
- ❑ May be lowest cost option
- ❑ No increase in envelope heating or cooling load

Disadvantages

Disadvantages relative to other approaches:

- ❑ Lower ceilings in some interior spaces

- ❑ Not suitable for all house designs, particularly those with rooms remote from central hallways
- ❑ Requires careful air sealing work by insulation contractor on unfamiliar locations
- ❑ Limited space available to HVAC contractor for duct installation
- ❑ Requires installation of second air barrier above duct space, i.e., the drywall forming the hallway ceiling provides one air barrier, and the top of the duct space forms a second.
- ❑ May require difficult coordination between subcontractors.
- ❑ Little or no access to ductwork for maintenance

Cathedralized Attic

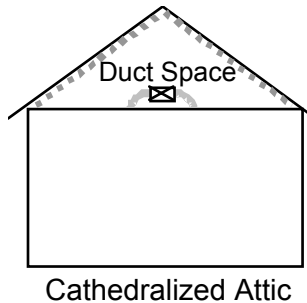

The Cathedralized Attic takes advantage of the fact that the roof is already weather tight to place the insulation immediately above or below the roof deck, using the roof deck as the air barrier. The roof is built without ridge or soffit vents, and all roof penetrations are sealed. Netting is installed between each roof truss to support insulation blown in immediately below the roof deck. Other methods of installing insulation may also be used, but the approach described has been successfully used in many houses.

By moving the air and thermal barriers to the roof line, the entire attic is made part of the conditioned space. The HVAC system is then installed in the attic in the normal way. If a gas furnace is being used, the mechanical code may require a direct vent unit.²

Attics which extend over unconditioned spaces, such as porches or garages, must have air and thermal barriers installed to separate conditioned from unconditioned space. Normally this will be done by either extending the roof sheathing or constructing a vertical partition in the attic using OSB on the outside of a truss. In either case, the partition must be air sealed using insulating foam or caulk, and fully insulated. The bottom of the attic partition must have a continuous air and thermal barrier connection to the barrier on the occupied level.

A potential issue with the Cathedralized Attic approach is that it does not comply with requirements in most building codes that the space under the roof deck be ventilated. One reason this requirement exists is to allow air circulation to cool the roofing material, and minimize the cooling load. In cold climates, attic ventilation serves to avoid moisture condensation on the underside of the roof deck, as well as helping to avoid ice dams.

To avoid cold-climate condensation in houses with unvented attics, some or all of the insulation is installed above the roof deck. Rigid insulation is sandwiched between two layers of sheathing material below the roofing material. This is done to maintain the temperature of the inside of the roof assembly above the average indoor dewpoint temperature. See the “designer” section below for further details on this.

In hot climates, unvented attics will slightly increase roofing material temperatures. For tile and shake roofs, common in California, this is not a problem. The increased temperature, however, may limit the use of asphalt shingles, because the increased temperature may decrease their life. Lack of

² The mechanical code can be read either way regarding installation of a natural draft furnace in an unvented attic. A natural draft furnace will normally meet the requirements of the National Fuel Gas Code on the basis that the attic is not a confined space, and high and low vents are therefore not needed. Clarification or a variance from the local code official should be obtained to use a natural draft furnace.

venting may also violate the manufacturer's warrantee. Some manufacturers have stated that use of their shingles in this application is acceptable, although this may have applied only to particular builders and developments.

The following text describes steps to install a cathedralized attic duct system, with details for everyone involved in home building. Details are shown in Figure 3.

Designer

1. Modify the drawing of the roof to eliminate attic, ridge, soffit and any other vents.
2. Review the building plans to determine where, if anywhere, the attic extends over unconditioned space, such as garages or porches. Considering the roof truss layout, determine where to install the air and thermal barrier separating the conditioned attic from the portion over or adjacent to unconditioned space. If the unconditioned space protrudes from the conditioned space perpendicular to the ridge line, the roof sheathing on the conditioned area can be extended to the end of the trusses. OSB is then used to close any remaining gaps. Alternatively, for other arrangements between the conditioned and unconditioned space, OSB or other sheet material can be installed vertically, on the outside of a truss or on purpose installed studs. In either case, gaps must be sealed with caulk or insulating foam, and the barrier is insulated to the same R-value as the rest of the roof or exterior walls.
3. Duct exhaust fans directly to the roof or gable end termination and seal the penetrations.
4. In cool or cold climates, determine the need for insulation above the roof sheathing. Find the lowest monthly average temperature for your location (for example, weather.com for a particular location has "averages and records" that provides monthly average temperatures). If this value is 45°F or more, no insulation is needed above the roof sheathing.³
 - If it is below 45°F, subtract this temperature from the heating indoor temperature. For example, Grass Valley, CA has a January average temperature of 40°F, which gives a temperature difference of 30°F (70°F – 40°F).
 - The insulation layers should be designed to maintain the inside of the roof deck above 45°F (the temperature at which condensation will occur for air that starts at 70°F and 40% RH). Subtract the coldest monthly average outdoor temperature from the target roof deck temperature (45°F – 40°F = 5°F).

³ The 45°F temperature is based on the dewpoint temperature of indoor air at 72°F, 40% humidity. The monthly average outdoor temperature is used on the basis that typical building materials have sufficient hygric buffer capacity to tolerate occasionally being wetted when the dewpoint exceeds the material temperature by a small amount. For additional information on this topic, see "Unvented Roof Systems" at www.buildingscience.com/resources/roofs/default.htm.

- Divide this result by the indoor-outdoor temperature difference ($5^{\circ}\text{F} / 30^{\circ}\text{F} = 0.17$).
- Multiply this ratio by the overall R-value required for the roof to find the minimum R-value that is needed above the roof sheathing. For example, if total ceiling insulation of R-38 is required, the rigid insulation above the roof sheathing will be at least R-6.5 ($38 \times 0.17 = 6.46$), with R-31.5 insulation under the roof deck.
- If the interior insulation is increased, the exterior insulation must be increased as well, such that the ratio of the exterior R-value to the total insulation R-value is at least 0.17.
- Check with the structural engineer or truss supplier that the insulation and additional sheathing layer are acceptable.

Roofer

1. If rigid insulation is required above the roof deck, install it between the roof sheathing and a plywood or OSB nail base for the roofing material. Do not use asphalt shingles without approval of the shingle manufacturer. Use tile or shake roofing.

Insulation Contractor

1. Seal around all roof penetrations.
2. Soffits must be insulated to prevent condensation on cold interior surfaces. Rigid insulation can be extended vertically from the exterior wall, notched around the roof trusses, and sealed. Figure 3 shows how this soffit air barrier can be installed.
3. Staple netting between each truss to provide support for dry blown insulation, typically cellulose. Fill the space between each truss, below the roof deck, with insulation to the depth needed to provide the required R-value. Note that the insulated area will be increased compared to conventional installation of insulation on the attic floor.

Figure 3. Insulating the Roof of a Cathedralized Attic

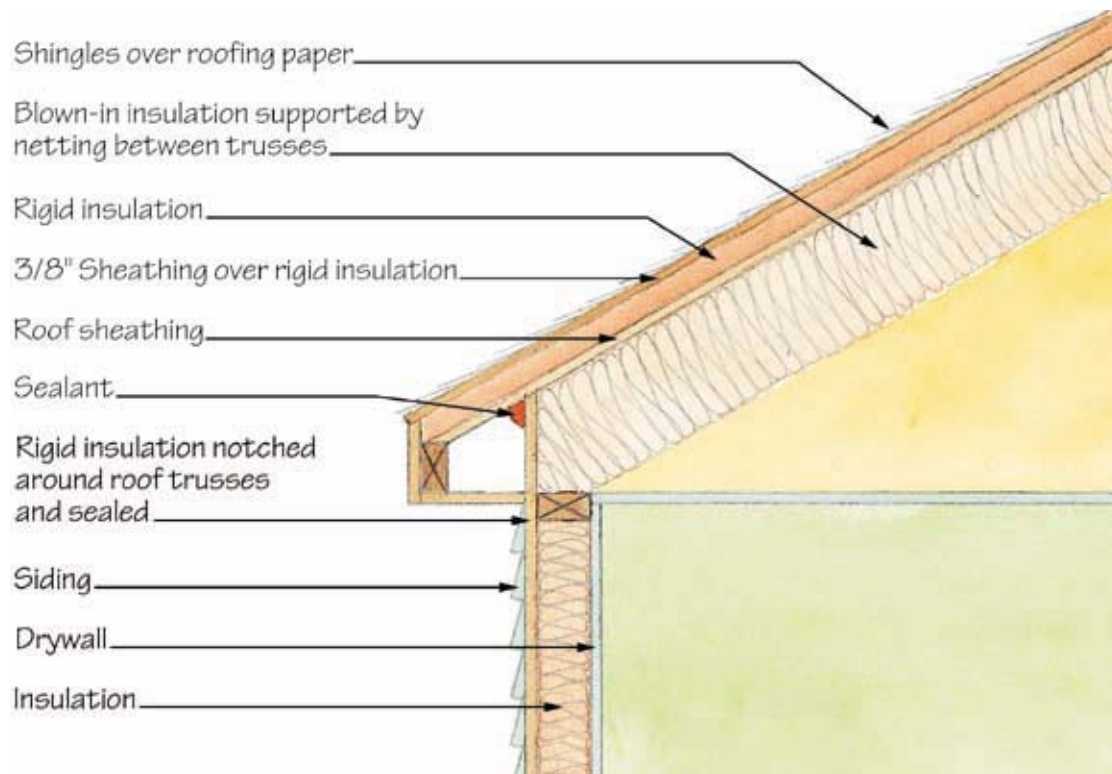

HVAC Contractor

1. Determine if installing ducts in the conditioned space will allow the HVAC system to be downsized. Perform careful sizing calculations following the ACCA Manual J procedure using proper factors for ducts located inside conditioned space. The capacity reduction varies by house size and climate, but should be in the range of $\frac{1}{2}$ to $1\frac{1}{2}$ tons of cooling capacity. Reductions will often, but not always, be sufficient to allow a smaller unit to be installed.
2. Install the HVAC system in the attic following usual practices. Natural draft gas furnaces may not be allowed under the mechanical code. Sealed combustion furnaces avoid the need for combustion air openings into the air handler location.

Advantages

The Cathedralized Attic approach to installing ducts in conditioned space has several advantages relative to other approaches:

- Can be applied to any floor plan which has a conventional attic with sufficient height
- No need to utilize valuable floor space for HVAC system equipment

- ❑ An additional air barrier does not need to be installed
- ❑ In mild or hot climates, only one trade (insulation contractor) needs to make major changes in construction techniques (there will be only minor changes for the roofers and framers)

Disadvantages

Disadvantages relative to other approaches:

- ❑ Code conflicts related to attic ventilation
- ❑ Increased insulated area (roof surface area is larger than the attic floor area) increases costs and heat transmitted
- ❑ Unvented attic increases cooling load (attic ventilation reduces cooling load somewhat and the surface area of the conditioned space is increased)
- ❑ In cold climates, two insulation layers and additional roof sheathing are required
- ❑ Common insulation contractor practice of “blow and go” must change
- ❑ Increased temperature of asphalt shingle roofing
- ❑ Increased difficulty in locating any water leaks in the roof

Plenum Truss

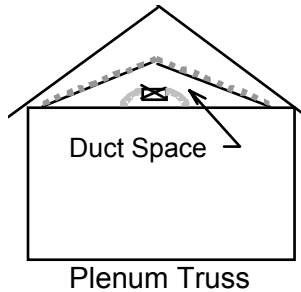

The Plenum Truss approach uses modified roof trusses which are designed to provide a space in the attic for installation of ductwork. The Plenum Truss approach to installing ducts in conditioned space falls between the Dropped Ceiling and Cathedralized Attic approaches in that part, but not all, of the attic is brought into conditioned space. Two alternative designs have been developed and tested, and they worked well (see Figure 4 below).

Figure 4. Plenum Truss Designs

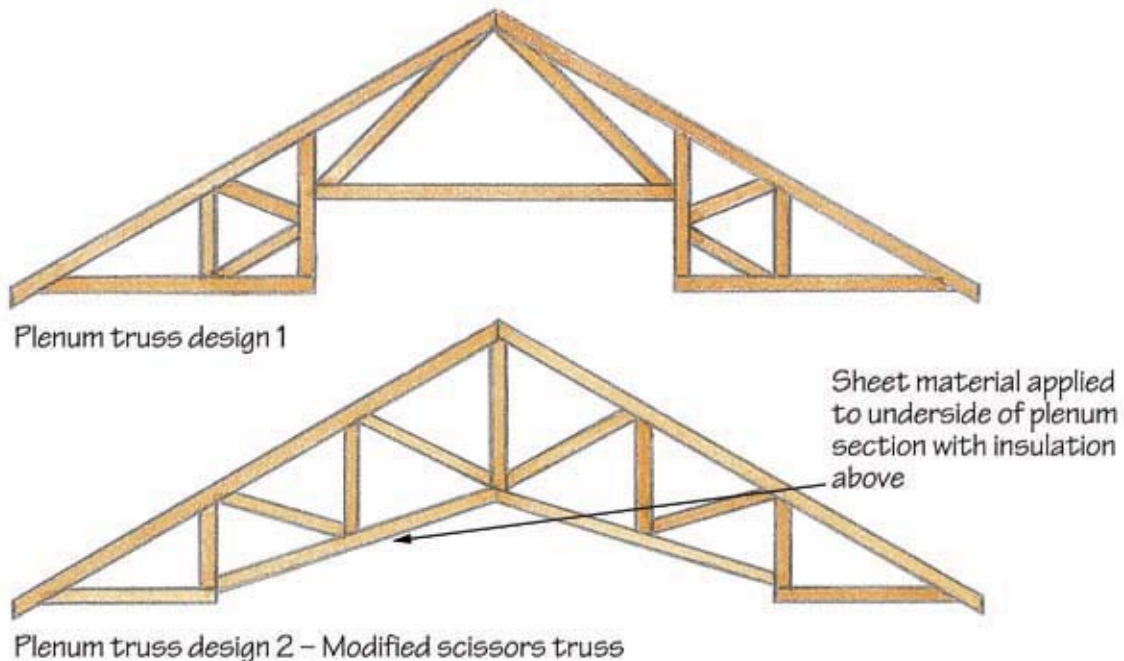

Note: Ceiling joists (not shown) must be added to support drywall for the ceiling of the space below.

The most recent design (Design 2 above) uses a modified scissors truss to provide space below the bottom chord of the truss that can be used for installation of the ductwork and HVAC system. Sheet material is installed on the bottom chord of the trusses and sealed to form the air barrier. Insulation is then blown in above the sheet material to form the thermal barrier. Roof systems are installed normally, with venting of the attic space above the air and thermal barrier. Ceiling joists need to be installed to support the ceiling

drywall. As with the other approaches, reduced duct runs are used with supply registers near interior walls.

The following text describes steps to install a plenum truss duct system, with details for everyone involved in home building. Details are shown in Figure 4.

Designer

1. Work with truss supplier to modify the roof truss design to provide space beneath the bottom chord.
2. Work with framing designer and truss supplier to determine ceiling joist requirements.

Framer

1. Install roof trusses and ceiling joists in accordance with requirements determined in Designer Steps 1 and 2.
2. Install sheet material, such as fiberboard, on bottom of the roof trusses.

Insulation Contractor

1. Seal all joints in the sheet material installed on the bottom of the roof trusses. A continuous air barrier must connect with the exterior wall drywall (the air barrier on the wall).
2. Install insulation on top of the sheet material. Note that the insulated area will be increased compared to conventional installation of insulation on the attic floor, although not as much as with the Cathedralized Attic.

HVAC Contractor

1. Determine if installing ducts in the conditioned space will allow the HVAC system to be downsized. Perform careful sizing calculations following the ACCA Manual J procedure using proper factors for ducts located inside conditioned space. The capacity reduction varies by house size and climate, but should be in the range of $\frac{1}{2}$ to $1\frac{1}{2}$ tons of cooling capacity. Reductions will often, but not always, be sufficient to allow a smaller unit to be installed.
2. Install the HVAC system and ductwork in the plenum space below the roof trusses and on top of the ceiling joists. Natural draft gas furnaces may not be allowed under the mechanical code. Sealed combustion furnaces avoid the need for combustion air openings into the air handler location.

Advantages

The plenum-truss approach to installing ducts in conditioned space has several advantages relative to other approaches:

- ❑ No building code impacts
- ❑ Allows conventional HVAC system installation in the attic plenum.
- ❑ Allows conventional ceiling insulation installation
- ❑ Vented attic above plenum minimizes cooling load

Disadvantages

Disadvantages relative to other approaches:

- ❑ High cost due to large area of additional air barrier and extra ceiling joists
- ❑ Specialized truss design may require extra cost and lead time

Multi-Story Houses

Houses with two or more stories typically have ducts in the attic serving the top floor with ducts run down through a chase or the exterior walls to the floor truss space for lateral duct runs to the spaces on the lower floor. The floor truss space is usually not inside conditioned space, because vertical penetrations for the chase as well as plumbing and wiring chases are typically open to the unconditioned attic. The perimeter band joist is also often not sealed well, providing additional air leakage paths to the outdoors.

For the top floor of these houses, any of the three approaches described earlier may be used to bring the duct system for the top floor into conditioned space. Bringing the portions of the duct system serving the lower floors into conditioned space is described below. The same general principal applies: the ducts must be inside the air and thermal barriers of the house in order to be inside conditioned space.

The first step in bringing the ducts serving the lower floors inside conditioned space is to identify appropriate locations that can be more easily sealed from the outdoors. In particular, do not use exterior wall cavities. These are outside the air barrier, which is normally the interior drywall. The best approach will often be to use a single chase from the attic, centrally located, with minimized lateral ducts in the floor truss space to interior register locations.

Figure 5. Sealing the Space Between Floors

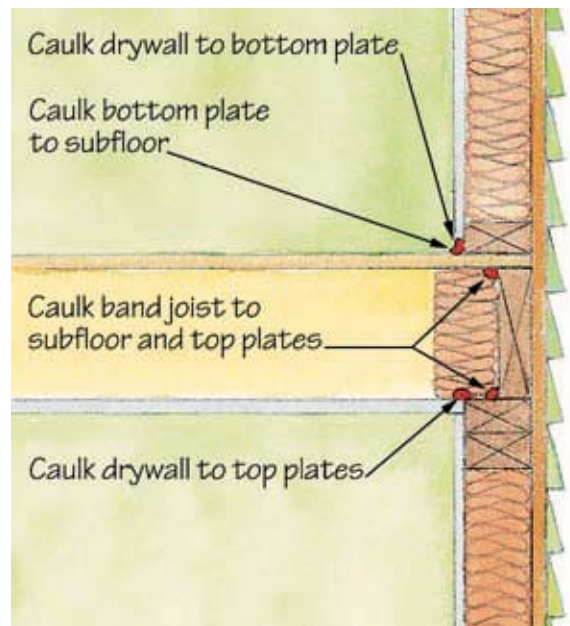

Note: Caulking of lower floor drywall to the top plates may be replaced by gluing the top of the wall drywall to the top plate. Either method may be used to seal the drywall to the plate, forming a continuous air barrier from the lower floor wall drywall to the top plate, band joist, subfloor and upper floor drywall.

Bringing the ducts inside conditioned space then involves sealing the floor truss space and the chase from the outdoors. First, the chase bringing the duct from the attic is connected to the cathedralized attic or duct space under the plenum trusses, and sealed from unconditioned space. Any plumbing or electrical chases that penetrate the truss space between floors must be sealed to avoid connections to unconditioned space and the outdoors. For a dropped ceiling, the chase may not connect directly to the duct space. It must be sealed at the top to avoid air leaks between the chase and the unconditioned attic. The connection between the dropped ceiling and the chase must also be sealed to avoid air leaks to the attic.

Bringing the floor truss space into the conditioned space requires sealing the top and bottom of the band joist (see Figure 5), and connecting it to the drywall air barrier. This means that the band joist needs to be caulked to the bottom plate and subfloor of the upstairs, and to the top plate of the downstairs walls. In addition, the drywall at the top of the downstairs walls should be glued or caulked to the top plate. Finally, the band joist must be insulated.

The following text describes steps to install a plenum truss duct system, with details for everyone involved in home building. Details are shown in Figure 5.

Designer

1. Determine the appropriate approach to use for the top floor. Follow steps for that approach. Consider the location of the chase needed for ducts to the lower floors.
2. Determine the duct size needed for the supply air to the lower level. Determine the dimensions of the chase needed to contain the duct.
3. Select a location for the duct chase to run from the attic or dropped ceiling duct space to the lower level floor truss space. Ensure that the chase does not have an air connection to the outdoors, such as through a stud space or plumbing chase that is not sealed.

Framer

1. Based on the approach selected for the top floor, follow steps for that approach as described earlier.
2. If the dropped ceiling approach is used for the top floor, provide sheet material (OSB, plywood, etc.) at the top of the duct chase to the lower floor which can be sealed to prevent air leaks from the chase to the attic.

Insulation Contractor

1. Based on the approach selected for the top floor, follow steps for that approach as described earlier.
2. Caulk the top and bottom of the band joist to the bottom plate and subfloor of the upstairs and to the top plate of the bottom floor. Install insulation on the interior of the band joist.

3. If the dropped ceiling approach is used for the top floor, seal the top of the duct chase from the attic using caulk or insulating foam around the sheet material provided by the framer.

HVAC Contractor

1. Based on the approach selected for the top floor, follow steps for that approach as described earlier.
2. Install ducts from the attic or dropped ceiling to the lower level. Interior supply register locations are desirable to minimize ductwork.

Drywall Contractor

1. Provide a seal between the top of the lower floor wall drywall and the top plate of the wall, either by gluing or caulking.

Appendix A.

Construction Protocols for Ducts in Conditioned Space

Introduction

Placing ducts in conditioned space involves modifying the design and construction of the house such that the duct system is located inside both the air barrier and the thermal barrier. Three approaches are used to make this change: Dropped Ceiling, Cathedralized Ceiling and Plenum Truss. Each approach, however, is used to find the best compromise between maximizing marketable floor area, minimizing energy cost, and minimizing construction cost impacts, while keeping the construction process as simple as possible.

In achieving these goals, standard protocols for all the subcontractors to follow have been developed. The protocols will guide, itemize and define the responsibilities of each trade in constructing the above three approaches to meet the requirements of designing/installing ducts in conditioned space. The designs/installs, if done accordingly per the Protocol, will enable builders to claim compliance credits (which they can use to trade off building features) and consumers to benefit from the energy savings and the comfort of a home with ducts in conditioned space. The Protocol will also help reduce lost time in the field because subcontractors will know their responsibilities and anticipate their next task to minimize delays. It will also improve field coordination and communication among subcontractors. Overall, the protocols will help expedite the construction process of the three approaches so they will not delay the regular construction schedule. Builders build as fast as they can and delaying the construction schedule would delay their completion date and increase costs, particularly construction financing.

There are many other unforeseen field issues in construction. Having a protocol will help to achieve quality designs and installations of ducts in conditioned space, minimize field confusion and delays that may occur.

1. Subcontractor/Field Coordination

The three approaches to installing HVAC duct systems in conditioned space are Dropped Ceiling, Cathedralized Attic and Plenum Truss. Detailed Protocols for each of these approaches, with alternative options within two of them, follow. For each of these approaches *the critical aspect is creating and/or installing the air barrier above the ducts and sealing it to the air barrier of the exterior walls, drywall.* The protocols below detail the variations to install each of these different approaches.

2. Dropped Ceiling Approach

2.1 General

2.1.1 Any electrical or plumbing penetrations through the air barrier must be carefully sealed, with insulating foam or caulk. The insulation contractor must systematically locate and seal all openings. If the air handler is located above the duct space and air barrier, the supply and return ducts penetrating the top of the duct space must also be carefully sealed.

2.1.2 If penetrations through the top of the duct space are made after insulation is installed, whoever makes the penetration must seal those openings when work is complete.

2.1.3 If a natural draft or induced draft furnace is located in an interior closet, care must be taken to provide adequate combustion air. Sealed combustion furnaces avoid the need for combustion air openings into the air handler location.

2.1.4 In these detailed discussions, take particular note of tasks by specific contractors which must be performed out of the normal sequence of typical home construction.

2.2 Subcontractor/Field Coordination

The Dropped Ceiling approach is applied to houses with high ceilings, 9 ft to 10 ft. In the hallways and other ancillary spaces a dropped ceiling is installed at 8 ft, with the ducts installed in the space between. The upper portion of the air barrier is installed on the underside of the bottom cord of the roof trusses. In Option #1 of this approach, the upper air barrier is conventional drywall sealed to top plates of interior and exterior walls across the entire ceiling. In Option #2, plywood or OSB sheets are installed above the ducts instead of drywall, and must be sealed, too.

2.3 Option #1—Steps in Constructing Duct Systems at Dropped Ceilings

2.3.1 This approach has the advantage that the HVAC system installation is unimpeded by any framing. It has the disadvantage that drywallers must return after HVAC installation to install additional drywall to close the bottom of the duct space.

2.3.2 **DRYWALL CONTRACTOR.** Install drywall on the entire ceiling, including the area above the dropped ducts, in the normal sequence of drywall installation.

2.3.3 **HVAC CONTRACTOR.** HVAC equipment and ductwork are then installed, with ducts suspended from ceiling or walls.

2.3.4 **FRAMER.** Framers then return to install framing for the bottom of the duct space, cutting through the drywall as needed to attach the additional framing to the wall studs.

2.3.5 **DRYWALL CONTRACTOR.** Drywallers must then return to close in the bottom of the duct space.

2.4 Option #2—Steps in Constructing Duct Systems at Dropped Ceilings

2.4.1 This approach has the advantage that each trade appears only once (assuming no callbacks), avoiding complex scheduling. It has the disadvantage that the HVAC system installation is into a relatively small framed space, making installation more difficult.

2.4.2 **FRAMER.** Add framing at the dropped ceiling level in the hallways and other areas as delineated in architectural plans. Also construct soffits where identified. Install sheet material (OSB, plywood, etc.) above the dropped ceiling duct spaces by nailing the sheets to the underside of the bottom cord of the roof trusses. Figure A-1 shows details of constructing the dropped ceiling. *It is important to note that these OSB/plywood sheets above the ducts must be sealed to air movement where they abut to wall framing and to one another. Refer to the drawing below and following discussion.*

Figure A-1. Detail of Dropped Ceiling for Option #2

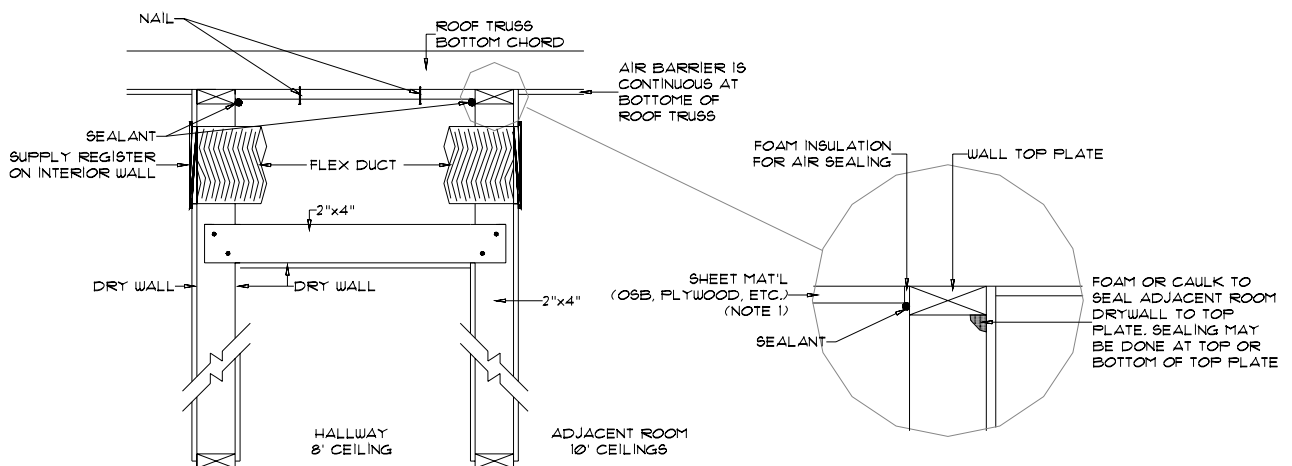

2.4.3 **HVAC CONTRACTOR.** After this framing is complete, HVAC and ductwork installation proceed. HVAC system is installed with the ducts in the dropped ceiling duct spaces. Supply registers are located on the interior walls adjacent to the duct space as per the architectural plans.

2.4.4 **DRYWALL.** Drywall is installed following usual practices.

2.4.5 **AIR BARRIER .**

2.4.5.1 Seal around the sheet material covering the duct space (see Fig. 1) using insulating foam. The connection between the ceiling drywall adjacent to the duct space and the wall top plate must be sealed as well using caulk or insulating foam. The objective is to provide a continuous air barrier at the level of the bottom of the roof trusses. In particular, this means that there must be no openings between the sheet material on top of the duct space, the wall top plate, and the adjacent ceiling drywall. Sealing is only required at the top of the duct space, forming a continuous air barrier at the level of the bottom of the roof trusses.

2.4.5.2 Any electrical or plumbing penetrations through the top of the duct space must be carefully sealed, with insulating foam or caulk. The insulation contractor must systematically locate and seal all openings. If the air handler is located above the duct space, the supply and return ducts penetrating the top of the duct space must also be carefully sealed.

2.4.6 **INSULATION CONTRACTOR.** Attic insulation may then be installed normally.

3. Cathedralized Attic Approach

3.1 General

3.1.1 Any electrical or plumbing penetrations through the air barrier must be carefully sealed, with insulating foam or caulk. The insulation contractor must systematically locate and seal all openings. If the air handler is located above the duct space and air barrier, the supply and return ducts penetrating the top of the duct space must also be carefully sealed.

3.1.2 If penetrations through the top of the duct space are made after insulation is installed, whoever makes the penetration must seal those openings when work is complete.

3.1.3 If a natural draft or induced draft furnace is located in an interior closet, care must be taken to provide adequate combustion air. Sealed combustion furnaces avoid the need for combustion air openings into the air handler location.

3.1.4 In these detailed discussions, take particular note of tasks by specific contractors which must be performed out of the normal sequence of typical home construction.

3.2 Roofer

3.2.1 If rigid insulation is specified above the roof deck, install it between the roof sheathing and a plywood or OSB nail base for the roofing material.

3.2.2 Do not use asphalt shingles without approval of the shingle manufacturer. Tile or shake roofing are recommended.

3.3 Insulation Contractor

3.3.1 **Seal all joints of roof decks to make them continuous air barriers. Give particular care in sealing the joints with the exterior walls, at the ridges and valleys of roofs.**

3.3.2 Attics which extend over unconditioned spaces, such as porches or garages, must have air and thermal barriers installed to separate conditioned from unconditioned space. Normally this will be done by either extending the roof sheathing or constructing a vertical partition in the attic using OSB on the outside of a truss. In either case, the partition must be air sealed using insulating foam or caulk, and fully insulated. The bottom of the attic partition must have a continuous air and thermal barrier connection to the barrier on the occupied level.

3.3.3 Seal around all roof penetrations.

3.3.4 Soffits must be insulated and air sealed to provide continuity of the insulation and air barriers between the outside walls and the roof. Rigid insulation can be extended vertically from the exterior wall, notched around the roof trusses, and sealed. Figure A-2 shows how this soffit air and thermal barrier can be installed.

Figure A-2. Detail of Wall Insulation Extension to Roof Insulation

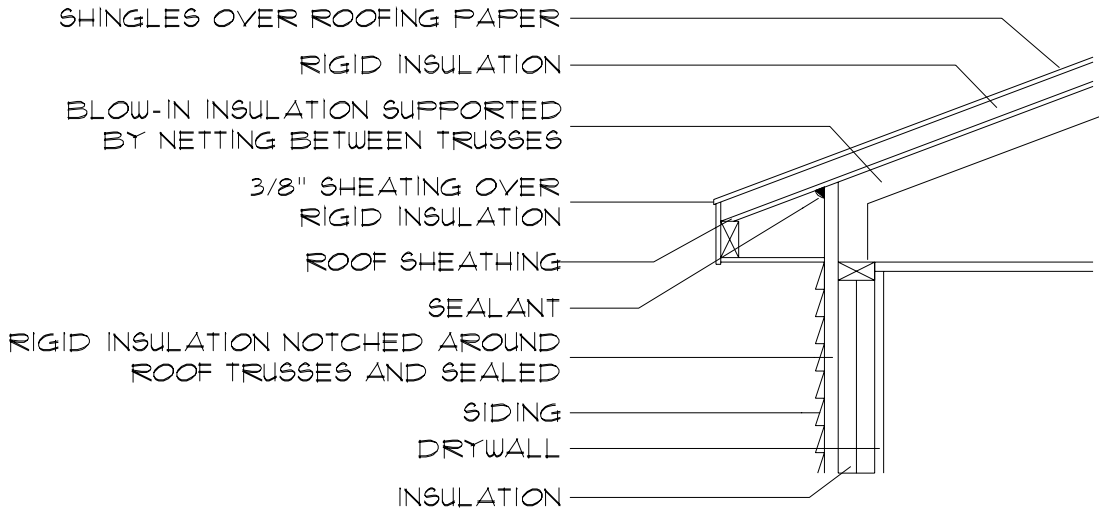

3.3.5 Staple netting between each truss to provide support for dry blown insulation, typically cellulose. Fill the space between each truss, below the roof deck, with insulation to the depth needed to provide the required R-value. At midpoints between trusses, depths of insulation must be greater than normal to achieve the required R-value, on average, due to the shallow depth of insulation near trusses. Note that the insulated area will be increased compared to conventional installation of insulation on the attic floor.

3.4 HVAC Contractor

3.4.1 Install the HVAC system in the attic following usual practices. Natural draft gas furnaces may not be allowed under the mechanical code. Sealed combustion furnaces avoid the need for combustion air openings into the air handler location.

4. Plenum Truss Approach

4.1 General

4.1.1 Any electrical or plumbing penetrations through the air barrier must be carefully sealed, with insulating foam or caulk. The insulation contractor must systematically locate and seal all openings. If the air handler is located above the duct space and air barrier, the supply and return ducts penetrating the top of the duct space must also be carefully sealed.

4.1.2 If penetrations through the top of the duct space are made after insulation is installed, whoever makes the penetration must seal those openings when work is complete.

4.1.3 If a natural draft or induced draft furnace is located in an interior closet, care must be taken to provide adequate combustion air. Sealed combustion furnaces avoid the need for combustion air openings into the air handler location.

4.1.4 In these detailed discussions, take particular note of tasks by specific contractors which must be performed out of the normal sequence of typical home construction.

4.2 Framing

4.2.1 Install roof trusses and ceiling joists in accordance with requirements determined by truss suppliers, architect and structural engineer. Install ceiling joists to support the ceiling drywall, typically at 8 ft height.

(Note: Roof systems are installed normally, with venting of the attic space above the air and thermal barrier).

4.2.2 Install sheet material, OSB or plywood, on bottom of the roof trusses.

The Plenum Truss approach uses modified roof trusses which are designed to provide a space in the attic for installation of ductwork and the air handler. Two alternative designs have been developed and tested, and have worked well (see Fig.A-3, below).

Figure A-3. Alternative Truss Designs

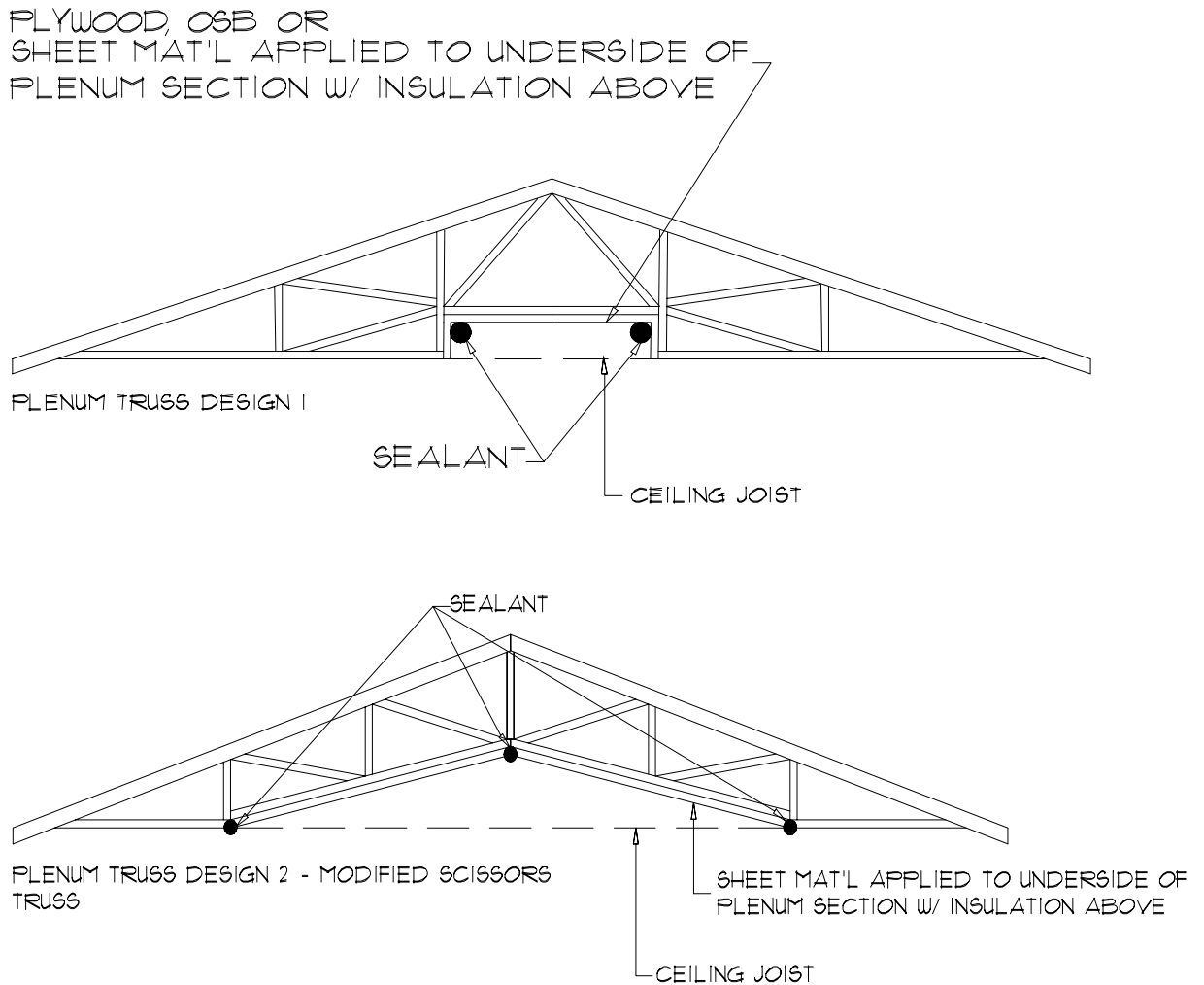

4.3 Insulation Contractor

4.3.1 Seal all joints in the sheet material installed on the bottom of the roof trusses. Ceiling drywall, interior wall top plates and the sheet material must provide a continuous air barrier connecting with and sealed to the exterior wall drywall (air barrier of exterior walls).

4.3.2 Install insulation on top of the sheet material from step 2. Note that the insulated area will be increased compared to conventional installation of insulation on the attic floor, although not as much as with the Cathedralized Attic.

4.4 HVAC Contractor

4.4.1 Install the ductwork in the plenum space below the roof trusses on top of the ceiling joists. Install HVAC system as per architectural plans and specifications.

4.5 Drywall Contractor

4.5.1 Drywall is installed following usual practice and is sealed to sheet material in duct space.

5. Multi-Story Houses

5.1 General

5.1.1 Houses with two or more stories typically have ducts in the attic serving the top floor with ducts run down through a chase or the exterior walls to the floor truss space for lateral duct runs to the spaces on the lower floor. The floor truss space is usually not inside conditioned space, because vertical penetrations for the chase as well as plumbing and wiring chases are typically open to the unconditioned attic. The perimeter band joist is also often not sealed well, providing additional air leakage paths to the outdoors.

5.1.2 For the top floor of these houses, any of the approaches described above may be used to bring the duct system for the top floor into conditioned space. Bringing the portions of the duct system serving the lower floors into conditioned space is described below. The same general principal applies: the ducts must be inside the air and thermal barriers of the house in order to be inside conditioned space.

5.1.3 The first step in bringing the ducts serving the lower floors inside conditioned space is to identify appropriate locations that can be more easily sealed from the outdoors. In particular, do not use exterior wall cavities. These are outside the air barrier, which the normally the interior drywall. The best approach will often be to use a single chase from the attic, centrally located, with minimized lateral ducts in the floor truss space to interior register locations.

5.1.4 Bringing the ducts inside conditioned space then involves sealing the floor truss space and the chase from the outdoors. First, the chase bringing the duct from the attic is connected to the cathedralized attic or duct space under the plenum trusses, and sealed from unconditioned space. Any plumbing or electrical chases that penetrate the truss space between floors must be sealed to avoid connections to unconditioned space and the outdoors. For a dropped ceiling, the chase may not connect directly to the duct space. It must be sealed at the top to avoid air leaks between the chase and the unconditioned attic. The connection between the dropped ceiling and the chase must also be sealed to avoid air leaks to the attic.

5.1.5 Bringing the floor truss space into the conditioned space requires sealing the top and bottom of the band joist (see A-4), and connecting it to the drywall air barrier. This means that the band joist needs to be caulked to the bottom plate and subfloor of the upstairs, and to the top plate of the downstairs walls. In addition, the drywall at the top of the downstairs walls should be glued or caulked to the top plate. Finally, the band joist must be insulated.

5.1.6 **The duct locations must be inside the air and thermal barriers.**

5.2 Framing

5.2.1 Based on the approach selected for the top floor, follow steps for that approach as described in sections 2, 3 or 4.

5.2.2 If the dropped ceiling approach is used for the top floor, provide sheet material (OSB, plywood, etc.) at the top of the duct chase to the lower floor which can be sealed to prevent air leaks from the chase to the attic.

5.3 Insulation Contractor

5.3.1 Based on the approach selected for the top floor, follow steps for that approach as described in sections 2, 3 or 4.

5.3.2 Caulk the top and bottom of the band joist to the bottom plate and subfloor of the upstairs and to the top plate of the bottom floor. Install insulation on the interior of the band joist.

5.3.3 If the dropped ceiling approach is used for the top floor, seal the top of the duct chase from the attic using caulk or insulating foam around the sheet material provided by the framer.

5.4 HVAC Contractor

5.4.1 Based on the approach selected for the top floor, follow steps for that approach as described in sections 2, 3 or 4.

5.4.2 Install ducts from the attic or dropped ceiling to the lower level. Interior supply register locations are desirable to minimize ductwork.

5.5 Drywall Contractor

5.5.1 Provide a seal between the top of the lower floor wall drywall and the top plate of the wall, either by gluing or caulking.

Figure A-4. Detail of Exterior Wall and Floor Joists

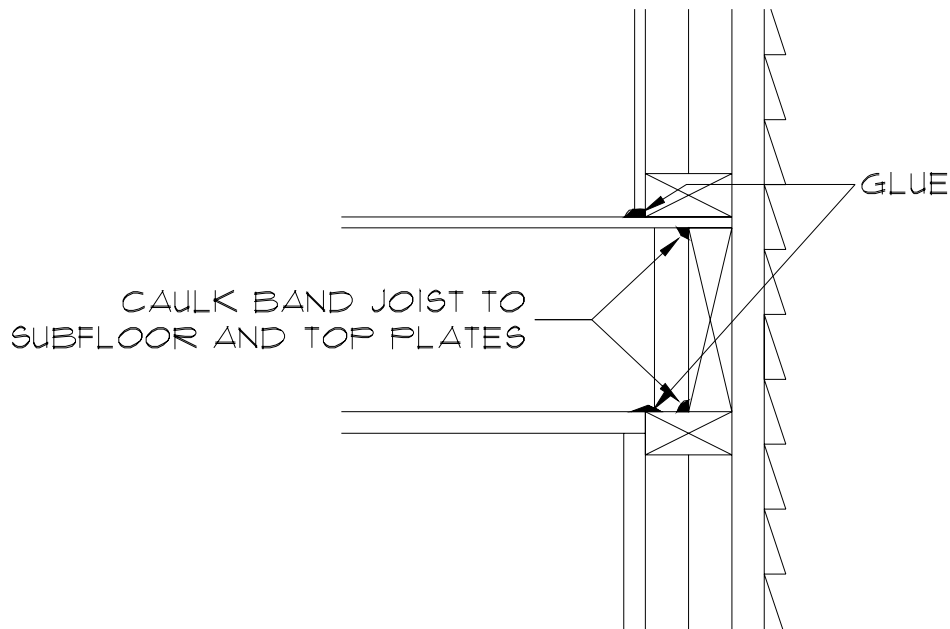

APPENDIX B.

California House Plans with Example Dropped Ceiling Locations

Figure B-1. One-Story House, Plan A

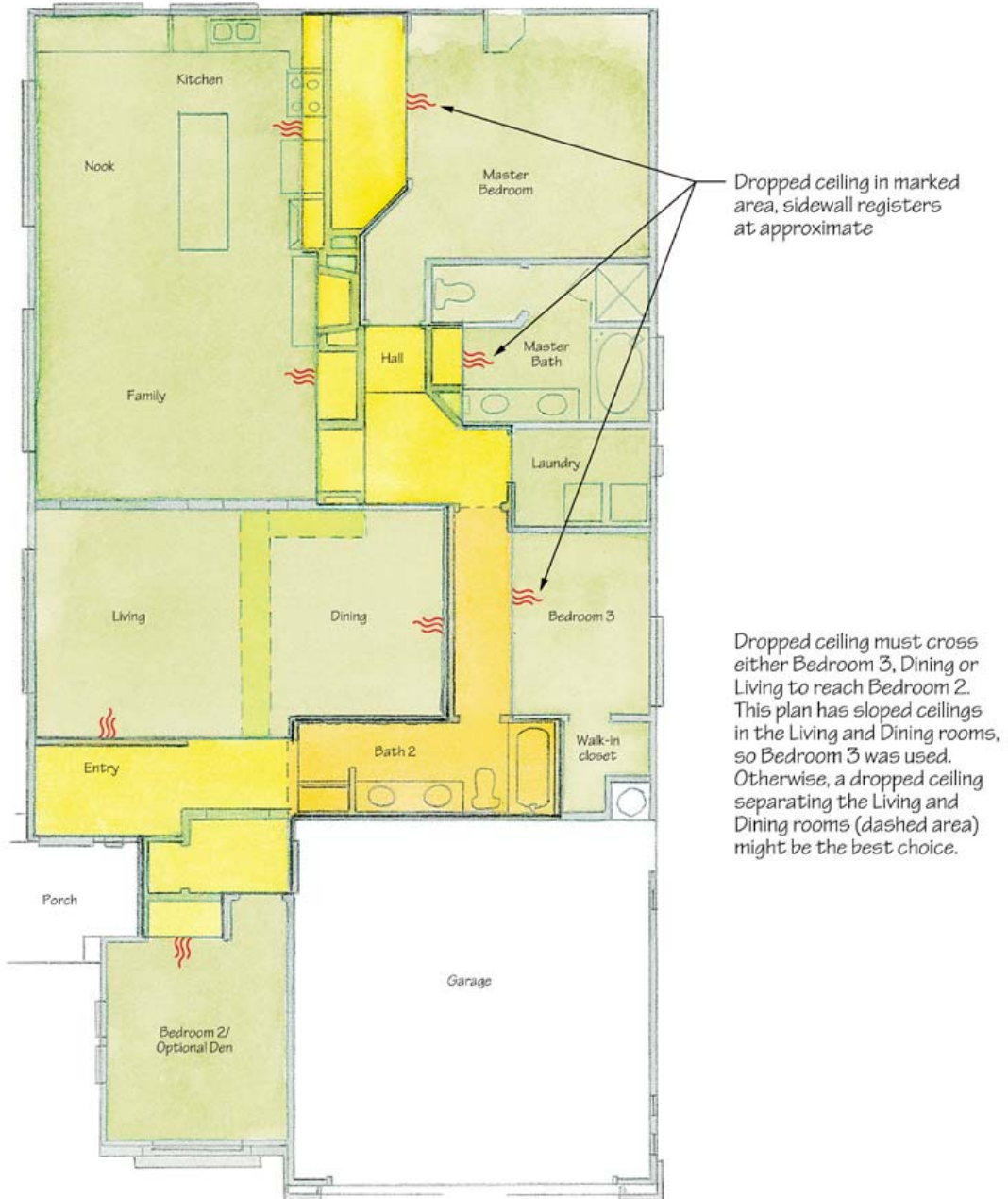
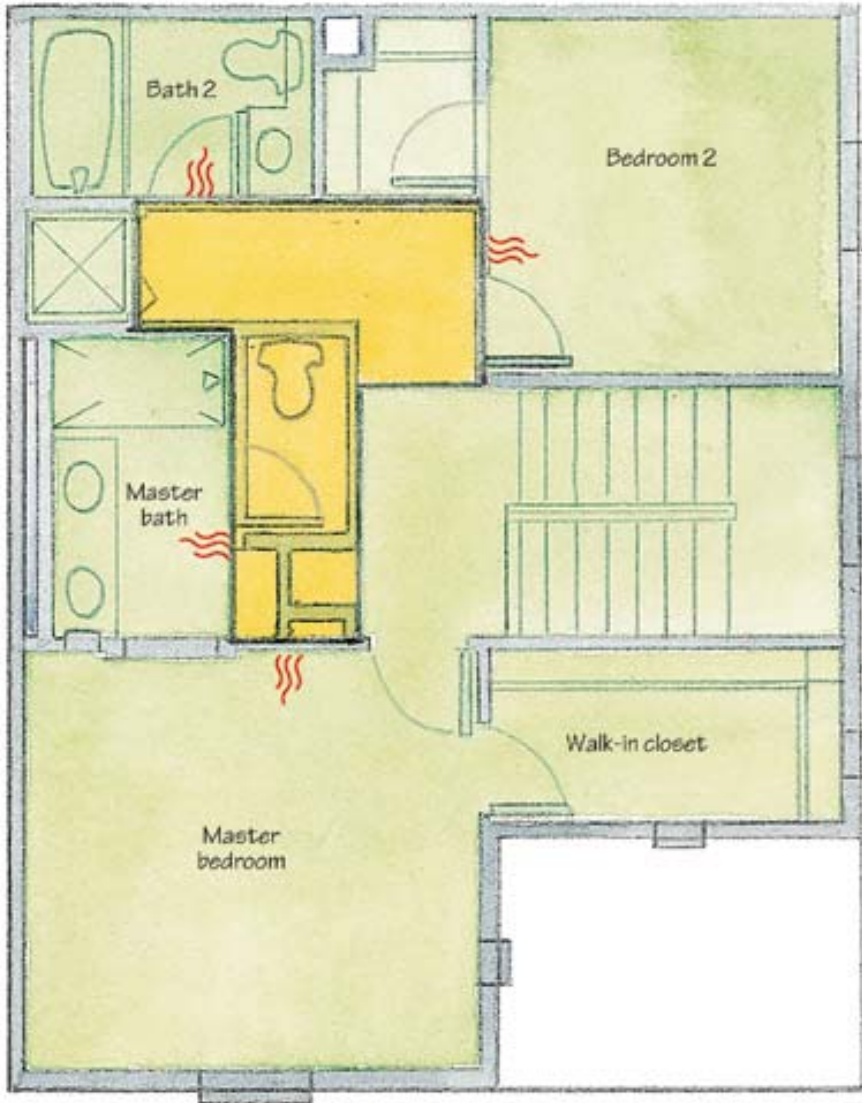

Figure B-2. Two-Story House, Plan B, Second Floor



Figure B-3. Townhouse, Plan C, Second Floor



APPENDIX C.

References & Additional Resources

National Association of Home Builders Research Center, www.nahbrc.org

- A Builder's Guide to the Placement of Ducts and HVAC Equipment in Conditioned Spaces
- www.toolbase.org/tertiaryT.asp?TrackID=&CategoryID=1308&DocumentID=2092, "HVAC Equipment and Duct Installation within Conditioned Space," 12/13/2001
- www.nahbrc.org/tertiaryR.asp?TrackID=&DocumentID=2725&CategoryID=1416, "PATH: Sustainable Community in Tucson Opens, Performance Monitoring Underway," 12/13/2001
- Field Evaluation of PATH Technologies: K. Hovanian's Idea House, Freehold, New Jersey
- Final Report for Field Evaluation of PATH Technologies: Warren Builders' Homes, Albertville, Alabama

Building Science Corporation, www.buildingscience.com

- www.buildingscience.com/resources/roofs/roofs_unvented.htm, "Unvented Roof Systems," 2/8/2002
- www.buildingscience.com/resources/roofs/attics_hotclimate.htm, "Vented and Sealed Attics in Hot Climates," 2/8/2002

Steven Winters Associates

(Author of articles appearing in various publications)

- "Cost-Effective, Energy-Efficient Residence," *ASHRAE Journal*, April 2001
- "Cost Effective Efficiency in Houston," *Home Energy magazine*, November/December 2001
- "Mercedes Homes Deploys Innovative New Truss," *Energy Design Update*, March 2001
- www.carb-swa.com/carbfax.html. Provides access to a monthly newsletter describing various projects. Pertinent issues include September 1999, December 1999, June 2000, September 2000, October 2000, November 2000, February 2001, April 2001, May 2001, July 2001, and December 2001

Home Energy Magazine Online

- www.homeenergy.org/archive/hem.dis.anl.gov/eehem/95/951104.html, "Researchers Approach Builders on Duct Location," 1/4/2002

ASHRAE, www.ashrae.org

- Standard 152, "Method of Test for Determining the Design and Seasonal Efficiencies of Residential Thermal Distribution Systems," 2003.

National Renewable Energy Laboratory

- www.osti.gov/bridge/product.biblio.jsp?osti_id=15003044&queryId=1&start=0, "Thermal Performance of Unvented Attics in Hot-Dry Climates: Results from Building America," NREL/CP-550-32827, January 2003